

(12) INTERNATIONAL APPLICATION PUBLISHED UNDER THE PATENT COOPERATION TREATY (PCT)

(19) World Intellectual Property Organization  
International Bureau



(43) International Publication Date  
21 December 2000 (21.12.2000)

PCT

(10) International Publication Number  
**WO 00/77883 A1**

- (51) International Patent Classification: H01P 11/00
- (21) International Application Number: PCT/US00/16138
- (22) International Filing Date: 12 June 2000 (12.06.2000)
- (25) Filing Language: English
- (26) Publication Language: English
- (30) Priority Data:  
09/333,716 15 June 1999 (15.06.1999) US
- (71) Applicant: CTS CORP. [US/US]; 905 West Boulevard North, Elkhart, IN 46514 (US).
- (72) Inventors: BLAIR, Raymond, G.; 9612 Giddings NE, Albuquerque, NM 87109 (US). ROMBACH, Edward, J.; 55 Tarpon Avenue, Rio Rancho, NM 87124 (US).
- SIMONS, Randal, N.; 11809 Persimmon Avenue NE, Albuquerque, NM 87111 (US). PASCO, Wayne, D.; 38 Vista de La Montana, Placitas, NM 87043 (US).
- (74) Agents: WESEMAN, Steven et al.; CTS Wireless Components, 1301 Algonquin Road, Bldg. IL02-0116, Schaumburg, IL 60196 (US).
- (81) Designated States (national): CA, CN, JP, KR.
- (84) Designated States (regional): European patent (AT, BE, CH, CY, DE, DK, ES, FI, FR, GB, GR, IE, IT, LU, MC, NL, PT, SE).
- Published:  
— With international search report.
- For two-letter codes and other abbreviations, refer to the "Guidance Notes on Codes and Abbreviations" appearing at the beginning of each regular issue of the PCT Gazette.



(54) Title: ABLATIVE METHOD FOR FORMING RF CERAMIC BLOCK FILTERS

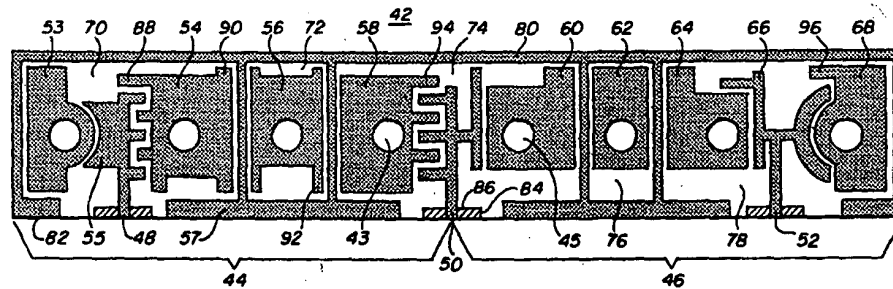

WO 00/77883 A1

(57) Abstract: A method of forming metallization patterns on a block of dielectric material wherein the entire surface area of the dielectric block is encased with a conductive material and unwanted conductive metal is ablatively etched from a designated surface area of the dielectric block to form desired metallized circuit patterns. The invention also comprises a filter and a duplexer formed by the method of the present invention.

## **ABLATIVE METHOD FOR FORMING RF CERAMIC BLOCK FILTERS**

### **BACKGROUND OF THE INVENTION**

#### **1. FIELD OF THE INVENTION**

This invention relates generally to electrical filters and relates particularly to filter apparatus and a method of forming so-called ceramic filters and duplexers.

## 2. DESCRIPTION OF RELATED ART INCLUDING INFORMATION DISCLOSED UNDER 37 CFR 1.97 AND 1.98

RF ceramic filters are well known in the art. They are constructed of blocks of ceramic material that are typically coupled to other electronic circuitry through discrete wires, cables, and pins coupled to conductive connection points on external surfaces of the blocks. They are also used to construct duplexers and other electronic components.

Ceramic block filters are used in wireless communication products. Three major process steps in the manufacture of these filters are: (1) the capacitive element pattern generation, (2) I/O pad generation, and (3) tuning the filter to the proper operating frequency. The function of the capacitive element pattern on the filter is to approximate the RF response required by the customer. The function of the I/O pad generation operation is to provide the interface from the filter to the wireless communication product. The function of the tuning operation is to finally adjust this approximated RF response to meet the exact customer requirements for the desired response.

In the prior art, a ceramic block is sintered and then silver metallic paste is placed on all sides of the block EXCEPT for those sides that require a defined electrical circuit such as a capacitive element pattern or input/output (I/O) pads. On those sides, the silver metallic paste is applied to the ceramic block in the form and shape of the desired pattern and the I/O pads (through a well-known screen print process technology or abrasion technology). A heating process causes the metallic paste to solidify with the pattern(s) and/or I/O pads generally in their proper location.

However, this screen print process does not have the dimensional accuracy desired in the plating of the capacitive element filter pattern and other filter elements. The capacitive element filter pattern dimensional accuracy on the ceramic block filters is required to be four times (4x) as accurate at 1.8 GHz as at 900 MHz.

Thus, in order to complete the product, the capacitive element filter pattern must be further tuned to meet exact customer specifications. This can be accomplished by adding excess metallic paste adjacent circuit pattern features and then using some method to sinter the metallic paste, forming an integral addition to the pattern or pads or, in some cases, material can be removed for tuning. By applying a signal to the input and monitoring the output signal during this process, the operator can terminate the addition of material to the pads or terminals when the output signal indicates that proper tuning has been achieved.

Thus, in U.S. Patent 5,198,788 fine tuning of ceramic filter metallic terminals or pads is disclosed. In this patent, the ceramic block is coated on all sides but one (and perhaps a portion of an adjacent side) and on the uncoated side (and portion), silver metallic paste is formed in the general shape of the desired electronic terminals, pattern, or pads. The silver metallic paste is heat-treated to form a rigid coating. Additional silver metallic paste is then placed adjacent and electrically contacting the formed terminals or pads and, while an input signal is being monitored on the output terminal, a laser beam is used to scan the silver metallic paste to sinter it and form a solid addition to the terminal or pad until the proper electrical characteristics of the device is obtained. Thus, this patent relates to the addition of metal to the already generally formed terminals, pattern, or pads to tune the circuit.

In U.S. Patent 5,769,988 there is disclosed a method of manufacturing a ceramic electronic component having a dielectric ceramic and a conductor thereon containing silver as the main component. By heat-treating the device, such as a dielectric resonator formed with that process, the "Q" value of the resonator is increased. In the process of heat-treating the device, it is disclosed that the device is subjected to a heat treatment at 400°C. or more in an atmosphere containing 10% or less by volume of oxygen. Further, Kagata, et al ('988) disclose "forming the conductive paste...in a pattern of electrodes" on the sintered dielectric ceramic substrate.

U.S. Patent 5,162,760 also relates to electrical filters formed of ceramic blocks using abrasive or milling methods to remove metallization or use various screen-printing techniques to apply conductive materials onto the various surfaces of the ceramic blocks. In the '760 patent, a layer of conductive material is deposited on the surface of the block and after the layer is successfully cured, portions of the conductive layer are removed by any suitable milling machine such that the desired conductive pattern is left on the surface. Both the conductive material coating the block and the dielectric material are removed from the block in the areas that are milled. This device is limited in accuracy or precision by the electrode dimension that can be formed with a milling machine.

In U.S. Patent 5,379,011 there is described a ceramic band-pass filter with improved input/output isolation and having conductive material removed from the metallization of the block and the I/O pads are deposited in those areas where the conductive metal had been removed. Again, in this patent, all six sides of the ceramic block are metallized with the exception of the top or upper surface and a portion of the side surface. Slots are formed, between the deposited input/output pads and adjacent metal in the ceramic material and thus, when not plated, varies the dielectric between the input/output pads.

It would be desirable to have such a filter with good isolation between conductive areas and having greater dimensional accuracy of the filter pattern and I/O pads than the present art can provide.

## SUMMARY OF THE INVENTION

In the present process, the ceramic block is formed in the usual manner. It has at least one planar surface. Then, instead of coating only those sides where the pattern or I/O pads are not to be formed, the ENTIRE ceramic block is coated with a conductive metallic material. One example of such metallic coating is a paste well known in the prior art and containing an electrically conductive metal (such as silver, for example only) and is then subjected to the necessary heat treatment to solidify the metal. Other examples of conductive coatings include plating the ceramic blocks with a conductive metal and the like.

An ablative method, such as the use of a scanning laser beam, is used to remove unwanted metallic material from at least one planar surface to form the desired capacitive element filter patterns. This differs from the abrasive method of the prior art or the screen printing of the prior art. The laser beam ablates both the metallization and a portion of the ceramic block to form trenches that surround metallic filter components and create the pattern in the desired shape. The depth and width of the trenches determine coupling capacitance of the filter and thus determine its operating frequency. The precision and repeatability of forming the trenches with the lasing process allows greater accuracy and repeatability of the capacitive element filter pattern and the other filter components. The more precise patterns allow for higher tune rates, higher factory yields, and more design margin for the product designers.

However, a well-known problem occurs as a result of the ablation process. During the lasing process, the ceramic material is adversely affected and the "Q" of the ceramic material is reduced to a point where the filter has no commercial value. Therefore a post-lasing, high-temperature heating process is required to restore the ceramic "Q" back to its approximate original value.

Since, during the ablation process, the capacitive element patterns and other filter components are being formed, a signal cannot be connected to the input pad for

monitoring at the output pad to see if the capacitive element patterns and the other filter components being formed are of the correct dimensions. After the filters have been formed, such signals cannot be applied and measured to the product specification because the ceramic block has such a reduced "Q" that they are only a generalized  
5 representation of the signals that would be found in a finished product. Therefore, for a given product specification, a trial-and-error ablation process is used by continuing to make metallized blocks with different dimension conductive patterns until signals representing the proper RF response range have been established to form a "reference" ceramic block. Since the lasing process is extremely precise and repeatable, great  
10 numbers of the reference device can then be produced and then a high temperature heating process is used to provide the proper RF response once the appropriate patterns have been generated.

Thus, it is an object of the present invention to provide a method of forming electrically conductive metallization patterns on a ceramic block that are electrically  
15 isolated from each other by a pattern of dielectric material.

It is still further an object of the present invention to provide a ceramic block that has its entire surface coated with a conductive material and to use a scanning laser beam to ablatively etch unwanted metallic material and corresponding ceramic material from the ceramic block and create trenches that form at least a portion of the pattern  
20 of dielectric material that establishes the desired metallization pattern.

It is also an object of the present invention to ablatively etch unwanted metallic material in such a way that a portion of the ceramic block is also removed sufficient to form trenches that electrically isolate adjacent metallic areas formed by the ablative etching.

25 It is another object of the present invention to ablatively etch unwanted metallic material from a designated surface area of the ceramic block to form trenches of dielectric material that create a desired metallization pattern, including input and output terminals.

It is still another object of the present invention to apply test signals to the input terminal of a post-lased, pre-heated ceramic filter and to monitor the output signal to determine by trial and error when a filter having the desired electrical characteristics is obtained.

5 It is yet another object of the present invention to heat the ablatively-etched ceramic block in an ambient atmosphere to restore the "Q" of the ceramic material.

Thus, the present invention relates to a method of forming ceramic block metallization patterns comprising the steps of encasing the entire surface of a ceramic block, including at least one planar surface, with a conductive metal, such as a metallic  
10 paste, for example only, solidifying the conductive metallic paste into a metallic material, and ablatively etching unwanted metallic material from a designated surface area of the ceramic block to form a desired metallization pattern, including input and  
output terminals if desired..

The invention also relates to a method of forming RF ceramic block filters  
15 comprising the steps of encasing the entire external surface area of a ceramic block with a conductive metallic material, using a pattern of dielectric material to electrically isolate and form electrically conductive circuit elements on the encased ceramic block, ablatively etching unwanted metallic material and a portion of the ceramic block from  
a designated surface area of the encased ceramic block to form at least one trench that  
20 forms at least a portion of the pattern of dielectric material and heating the ablatively-etched ceramic block to increase the "Q" thereof.

The invention also relates to trench filters and duplexers in which each  
conductive element formed in a ceramic block whose entire surface is encased in a  
conductive material, each of the conductive elements being at least partially  
25 surrounded by a trench or recessed area extending through the conductive material and into the ceramic block, the recessed area having a predetermined depth and width to affect the coupling capacitance of the filter or duplexer and thus control an operating characteristic of said filter or duplexer.



**BRIEF DESCRIPTION OF THE DRAWINGS**

These and other features of the present invention will be more fully disclosed when taken in conjunction with the following Detailed Description of the Preferred Embodiment(s) in which like numerals represent like elements and in which:

5                   FIG. 1 is a perspective view of a prior art ceramic band-pass filter adapted for tuning by adding material thereto;

                  FIG. 2 is a perspective view of a ceramic block of the present invention entirely encased with an electrically-conductive material such as a metallic paste;

                  FIG. 3 is a top view of a duplexer formed by the method of the present invention;

10                   FIG. 4 is a side view of the duplexer of FIG. 3 illustrating the conducting pads or terminals formed thereon and the trenches formed around the conductive filter elements;

                  FIG. 5 is a flow diagram illustrating the novel steps of the present invention;

15                   FIG. 6 is a graph illustrating the frequency response of a plurality of prior art filters shown in FIG. 1;

                  FIG. 7 is a graph illustrating the frequency response of a plurality of filters formed by the present inventive process after lasing but before high temperature heat processing; and

20                   FIG. 8 is a graph illustrating the frequency response of a plurality of filters formed by the present inventive process after firing to restore the "Q" of the ceramic.

**DETAILED DESCRIPTION OF THE PREFERRED EMBODIMENT(S)**

FIG. 1 is a perspective view of a prior art ceramic band-pass filter. Filter 10 is formed of a ceramic block with some surfaces having a conductive metal plate thereon and includes a top face 12, a bottom face 14, side faces 16 and 18, and end faces 20 and 22. Filter 10 further comprises parallel cylindrical bores 24 and 26 that openly extend between top face 12 and bottom face 14. Regions of the ceramic block surfaces, such as top surface or face 12, are screen-printed, in a well-known manner, with conductive metal material such as a silver paste to form metallic elements of the filter leaving the bare ceramic surface material of the ceramic block between the filter elements. The printed elements 36 and 38 rise above the top face of planar surface 12 of the ceramic block and include an input pad 28 and an output pad 30 that may wrap around between top face 12 and side face 16. The wraparound configuration is particularly adapted for surface-mount connections when a filter is subsequently incorporated into an electronic package. The side faces 16 and 18, bottom face 14, and end faces 20 and 22 are covered with a continuous metal plate that forms a ground element 32. At face 16, ground plate 32 is separated from input pad 28 and output pad 30 by bare ceramic regions 34 and 35 to prevent electrical short-circuiting. These bare ceramic regions 34 and 35 are created when the I/O pads are screen-printed on the ceramic substrates. Through-holes 26 and 28 are coated with conductive metal that extends onto the top face 12 to include the resonator pads 36 and 38 that are surrounded by bare ceramic surface. In accordance with the prior art, pads 36 and 38 include notches 40 and 42 for tuning the filter.

The prior art filter as shown in FIG. 1 has a thick film of metallic paste applied to the major surfaces, except for faces 12 and 16 and also to through-holes or cavities 24 and 26 by spraying, screen-printing, or other well-known process. The film of conductive paste is screen-printed in the desired pattern onto top surface 12 and side surface 16. The filter can be tuned as described more fully in U.S. Patent 5,198,788.

Thus, in the prior art, a ceramic block is sintered and then silver metallic paste is placed on all sides of the block except for those sides that require a defined capacitive element pattern or input/output (I/O) pads. On those sides, the silver metallic paste is applied to the ceramic block in the form and shape of the desired pattern and pads (through a well-known screen-print process technology) thus forming  
5  
conductive surfaces that are above the planar surface 12 of the ceramic block. A heating process causes the metallic paste to solidify with the patterns and/or I/O pads generally in their proper locations. However, this screen-print process does not have the dimensional accuracy desired in the plating of the capacitive element filter pattern.  
10  
The capacitive element filter pattern dimensional accuracy on the ceramic block filters is required to be four times greater (4x) at 1.8 GHz as required at 900 MHz. The ~~dimensional accuracy of the screen-printing process is capable of producing acceptable~~ 900 MHz filters. However, above 900 MHz, the frequency response continually degrades thereby producing smaller and smaller numbers or quantities of filters having  
15  
an acceptable frequency response. Therefore, in order to complete the product, the capacitive element filter pattern must be further tuned to meet exact customer specifications. This can be accomplished by adding excess metallic paste to adjacent pattern features (e.g. slots 40 and 42 in FIG. 1) and then using some method to sinter the metallic paste, thus forming an integral addition of metal to the pattern or pads.  
20  
By applying a signal to the input terminal and monitoring the output signal at the output terminal, the operator can cease the addition of material to the pads or terminals when the output signal indicates that proper tuning has been achieved. See U.S. Pat. No. 5,198,788 incorporated herein by reference.

FIG. 2 illustrates a perspective view of a ceramic block of the present invention  
25  
entirely encased with a conductive metal. The conductive metal may be plated thereon or may be formed with an electrically-conductive metallic paste that has been heated to solidify it. The block 40 has an internal ceramic portion 39 entirely encased, on all of its outside surfaces, including capacitive adjusting through-holes 43 and 45, with

the conductive metal. Only two through-holes are shown but, obviously, more can be included as shown in FIG. 3. Thus, instead of coating all sides except for the sides where the pattern or I/O pads are to be formed, the entire ceramic block is encased with a conductive metal such as, for example only, an electrically-conductive metallic paste (well known in the art) that is subjected to the heat treatment to solidify the metal.

5 A duplexer 42 using filters formed with the process of the present invention is illustrated in FIG. 3. It comprises a transmitter portion 44 and a receiver portion 46. It includes an I/O pad 48 for the transmitter (not shown), an antenna pad 50 for  
10 coupling signals to and from the transmitter portion 44 and the receiver portion 46, and an I/O pad 52 for connecting signals to the receiver (not shown). The transmitter portion 44 of the duplexer 42 includes resonators and associated circuit elements 53, 54, 55, 56, and 58 while the receiver portion 46 uses resonators and associated  
15 elements 60, 62, 64, 66, and 68. FIG. 3, before the circuit elements are formed thereon, looks like the block in FIG. 2 and the upper surface 41 has metal and corresponding ceramic ablatively removed therefrom to provide a pattern of dielectric material that forms, and electrically isolates, the circuit elements 53, 54, 55, 56, 58, 60, 62, 64, 66, and 68. It should be noted that the term "electrically isolates" as used  
20 herein means "no direct electrical connection". That is, there no longer is electrical continuity or connection between "isolated" conductive elements. There may be, however, electrical "coupling" between adjacent elements by means of electromechanical coupling (a piezoelectric effect) or alternating current (AC) coupling as through a capacitive effect. Note that in areas 70, 72, 74, and 78 that the metal and a corresponding portion of the ceramic material have been removed by an ablative  
25 process. This ablative process, preferably performed with a scanning laser beam, removes not only the conductive metal but also a corresponding portion of the dielectric block to form "trenches" or recessed areas 70, 72, 74, 76, and 78. These trenches have a depth and a width in any given portion of the filter pattern that affects

the coupling capacitance between adjacent metallic surfaces in a well-known manner and thereby affects electrical characteristics of the filters such as frequency of operation and impedance. Of course, if desired, some of the conductive elements could be formed by the prior art method of screen-printing and the outer edges thereof  
5 trimmed by a laser beam according to the present invention, to accurately control the conductive elements. The remainder of the patterns of dielectric material could be formed by the present novel process. In such cases, however, the trench forms at least 10%, and preferably in the range of about 70% to about 90%, of the pattern of dielectric material electrically isolating the electrical circuit pattern elements.

10 Thus, for the duplexer 42 shown in FIG. 3, it is formed from a block of dielectric material having multiple surfaces including at least one planar surface such as the block illustrated in FIG. 2. It also has a layer of metallic material coating all sides of the multiple surfaces of the block of dielectric material also as shown in FIG. 2. A ground plane 80 is formed by at least some of the metallic surfaces as illustrated in FIG. 3 by  
15 conductive material 82. A receiver filter 46 is formed in a first area of at least one planar surface of the block of dielectric and includes a first plurality of conductive elements 60, 62, 64, 66, and 68. A trench or recessed area 74, 76, and 78 surrounds each of the conductive elements to electrically isolate them and is recessed to a predetermined depth and has a predetermined width to cause a capacitive coupling  
20 between the conductive elements and the ground plane that determines an operating characteristic of the receiver filter such as the operating frequency.

In like manner, the transmitter filter 44 is formed on a second different area of the at least one planar surface of the dielectric block shown in FIG. 2 and includes a second plurality of conductive elements 53, 54, 55, 56, and 58 that has the trenches  
25 70, 72, and 74 that surround each of the plurality of conductive elements forming the transmitter portion 44. Again, these trenches are ablatively removed and extend through the conductive metallic material and into the dielectric material. Thus, a second capacitive coupling is formed between the conductive elements of the

transmitter 44 and the ground plane that, again, provides a capacitive coupling that is determined by the depth and width of the trenches or recessed areas and determine the operating frequency of the transmitter filter. First and second terminals 48 and 52 for the transmitter and the receiver, respectively, are formed on the top and side of the coated dielectric block such as shown as in FIG. 1 and in FIGS. 3 and 4. A third terminal 50 receives an antenna connection and is electrically coupled to the receiver filter and the transmitter filter in a well-known manner. It conveys the RF signals between the antenna and the RF receiver and the RF transmitter.

One or more through-holes such as 43 and 45, well known in the prior art, are plated with conductive matter to create resonate circuit elements.

If it is desired to fine-tune the filter, metal can be ablatively removed from areas such as, for example only, 88, 90, 92, and 94 to fine-tune the transmitter. The receiver 46 can be tuned in like manner. In this case, again, the ablative etching will remove both the metal plate and the ceramic to a desired depth.

FIG. 4 is a side view of the duplexer of FIG. 3. All of the elements shown therein are enlarged and not to any proportion. However, it can be seen in FIG. 4 that on the side 82 the transmitter terminal 48 extends down the side of the block and an area of conductive metal 82, shown at 84, is removed from around the terminal 48 thus exposing the ceramic 86. In like manner, the conductive elements 53, 54, 55, 57, and 58 shown on top of the ceramic have been formed by the creation of the trenches or recesses as set forth in the discussion of FIG. 3.

The same construction can be shown in relation to the third terminal 50 and the second terminal 52.

The important matter to consider here is that the block has been entirely coated with a conductive metal and that the patterns have been formed on the surface by ablatively etching away unwanted material to a desired depth and width to provide the proper operating characteristics of the filter. It will be noted in FIG. 4 that the surfaces of the conductive elements are at the same elevation as the surface 41 of FIG.

2 and FIG. 4. In other words, there is no formation of conductive elements on top of the ceramic but rather a deletion of metal as well as of the ceramic block by using the ablative method. This is entirely different from the prior art filter elements formed on top of and above the surface of the dielectric block and the terminals on the side of the block are formed by screen printing.

As stated earlier, however, a portion of the conductive metallic material may be formed, as in the prior art, with screen printing and then the remainder of the conductive metallic circuit patterns may be formed by the ablative etching as heretofore described.

FIG. 5 discloses a flow chart illustrating the novel steps of the present invention. At step (A), the entire surface of the ceramic block is coated with a conductive metal, preferably a metallic paste. At step (B), the conductive metal is solidified into a metallic material such as by heating the metallic paste and to cause it to adhere to the corresponding ceramic block. At step (C), unwanted metallic material and a portion of the corresponding ceramic block is ablatively etched away to form the desired metallic pattern on the block including I/O terminals. Of course, I/O terminals could be added on the side by some other method, such as screen printing as explained earlier and could then be electrically coupled to the metallic patterns that are formed on the top surface by ablatively etching.

At steps (D) and (E), the prototype filter is electrically checked. At step (D), an input signal is connected to the input terminal and, at step (E), an output signal at the output terminal is monitored to determine the electrical characteristic of the ablated ceramic block.

At step (F), steps (A) through (E) are repeated until a ceramic block having approximate desired electrical characteristics is obtained. At that time, the ceramic block filters can be mass-manufactured and, at step (G), heated in an ambient atmosphere to increase the "Q" thereof. Of course, an ablated ceramic block could be heated to restore the "Q" and then, if the proper filter response is found, the ceramic

block filters could be mass-manufactured, heated, and quality control provided to ensure filters having the desired characteristics.

FIG. 6 is a graph of the frequency response of a plurality of filters formed with the prior art process of printing the circuit on the ceramic block surface. Note that the peak insertion loss is -1.2 dB and the frequency standard deviation is 2.63 MHz. It can be seen that on each end of the curve that there is a great deal of variation and response among the filters, thus changing the bandwidth of the devices.

FIG. 7 is a graph of a plurality of filters made with the novel method of the present invention. Note how closely they all respond all across the graph and especially across the bandwidth at the top. This graph illustrates the frequency response of a plurality of the devices after the lasing process to create the filter circuit elements but before they have been heated to restore the "Q". Therefore, notice that the peak insertion loss is 5.4 dB. However the center frequency deviation has been reduced to .85 MHz.

FIG. 8 is a graph of the same ceramic filters made with the process of the present invention and shown in FIG. 7 after they have been heated to restore the "Q". Again, notice how closely they replicate each other and the peak insertion loss has now been reduced to -1.2 dB and center frequency standard deviation is 0.75 MHz.

Thus, it can be seen there is a significant improvement in the operation of the filters made under the process of the present invention.

Thus, there has been disclosed a novel process and apparatus in which process two major steps are included. The first is that all of the surfaces of the ceramic block are covered with plated metal and, second, that at least some of the desired filter circuit patterns are formed by ablatively etching unwanted materials from one or a portion of a second surface of the plated ceramic block ablating both the metal and underlying ceramic.

The first novel step differs from the prior art in that in the prior art one or more surfaces are left uncoated and then the patterns are plated thereon, thus the patterns



have a top surface that rises above the top surface of the ceramic block. In the present application, because the metal surfaces of the patterns formed are coplanar with the other metal surface that was not removed on the block, tuning simply requires removing additional metal from the metal circuit patterns. Further, the ablative  
5 technique used to remove the metal also removes a portion of the dielectric, thus creating a trench or recessed area around each of the conductive elements of the filter circuit pattern to electrically isolate them. The width and depth of these recessed areas determine the operating parameters of the filter such as the operating frequency.

The second step of ablatively etching away unwanted material and dielectric not  
10 only to form the metal filter circuit patterns but also to determine the frequency response of the filter is novel since, in the prior art, a laser was used only to add metal  
to tune the filter circuits.

The corresponding structures, materials, acts, and equivalents of all means or  
step plus function elements in the claims below are intended to include any structure,  
15 material, or act for performing the function in combination with other claimed elements as specifically claimed.

**WHAT IS CLAIMED IS:**

1. A method of forming metallization patterns on a block of dielectric material comprising the steps of:

forming a dielectric block having a surface area including at least one planar surface;

5 encasing the entire surface area of said dielectric block with a conductive metal; and

ablatively etching unwanted conductive metal from said at least one planar designated surface area of said dielectric block to form at least some desired metallized circuit patterns.

10

---

2. The method of claim 1 further comprising the step of forming said dielectric block of a ceramic.

3. The method of claim 2 wherein the step of encasing the entire surface area of said dielectric block with a conductive metal further comprises the steps of:  
5 using an electrically conductive metallic paste as said conductive metal;  
and  
solidifying said conductive metallic paste into a metallic material.

4. The method of claim 1 further comprising the step of heat treating said  
10 conductive metal prior to said ablative etching to cause adherence of said conductive metal to said dielectric block.

5. The method of claim 2 further comprising the step of heating said  
15 ablatively etched ceramic dielectric blocks in an ambient atmosphere to increase the "Q" of said ceramic dielectric block.

6. The method of claim 1 further comprising the step of using a laser beam to ablatively etch unwanted metal and form said desired metallized circuit pattern as  
20 a circuit for receiving RF signals.

7. The method of claim 1 wherein the step of ablatively etching unwanted metallic material also removes a portion of said dielectric block to a depth sufficiently below said at least one planar surface to form a trench to electrically isolate adjacent  
25 metallic areas formed by said ablative etching.

8. A method of forming RF ceramic block filters comprising the steps of:
- (1) coating the entire external surface area of a ceramic dielectric block with a conductive metal;
  - (2) causing said conductive metal to adhere to said ceramic block; and
  - 5 (3) ablatively etching unwanted conductive metal and a corresponding portion of said ceramic block from a designated surface area of said coated ceramic block to form desired metallized filter circuit patterns.

9. The method of claim 8 further comprising the steps of:  
ablatively removing a portion of said ceramic block and corresponding  
conductive metal to form a trench having a predetermined depth and  
width sufficient to effectively isolate at least some conductive  
metallic areas adjacent said filter circuit patterns and to establish a  
predetermined capacitive coupling between adjacent metallic areas;  
and  
forming input and output terminals on a surface area of said coated  
ceramic block for coupling electrical signals to said desired  
metallized circuit filter patterns.
10. The method of claim 9 further comprising the steps of:  
(4) coupling an input signal to said input terminal;  
(5) monitoring an output signal at said output terminal to determine at  
least one electrical characteristic of said ablated ceramic block filter;  
and  
(6) repeating the steps (1) through (5) until at least one desired electrical  
characteristic of said filter is obtained.
11. The method of claim 10 further comprising the step of:  
(7) manufacturing predetermined quantities of the ceramic block filters  
having the desired electrical characteristic.

12. The method of claim 11 further comprising the steps of:
  - (8) heating each of said manufactured ceramic blocks; and
  - (9) utilizing an ambient atmosphere during said heating of said ceramic blocks to increase the "Q" of said ceramic blocks.

13. A method of forming an RF filter comprising the steps of:  
forming a block of dielectric material having multiple surfaces including  
at least one planar surface;  
coating a layer of electrically conductive metallic material on all of the  
multiple surfaces of said block of dielectric material; and  
ablatively removing trenches of selected areas of dielectric material and  
metallic material from at least a portion of said at least one planar  
surface to form an electrical RF filter pattern of conductive metal  
providing a predetermined filter frequency response.

5

10

---

14. The method of claim 13 further comprising the step of:  
forming said trenches in said selected areas with a predetermined depth  
below said planar surface of said at least one of said dielectric block  
surfaces and with a predetermined width; the depth and width of  
said trenches establishing the frequency response of said filter.
- 5
15. The method of claim 13 further including the step of:  
ablatively removing metallic material and corresponding dielectric material  
from at least one of said ceramic block surfaces to form a first  
terminal as an input terminal and a second terminal as an output  
terminal.
- 10



16. A method of forming a duplexer circuit for an RF transmit/receive circuit comprising the steps of:

forming a block of dielectric material having multiple surfaces including at least one planar surface;

5 adhering a layer of electrically conductive metallic material on all of the multiple surfaces of said block of dielectric material;

ablating a first selected area of metallic material and corresponding dielectric material from said at least one planar surface to first predetermined depths and widths to form a first electrical filter circuit pattern of electrically isolated conductive elements having a first predetermined filter frequency response;

10 ablating a second different selected area of metallic material and corresponding dielectric material from said at least one planar surface to second predetermined depths and widths to form a second electrical filter circuit pattern of electrically isolated conductive elements having a second predetermined filter frequency response; and

15 forming a first terminal as an input terminal and a second terminal as an output terminal, said first and second terminals being formed on at least one of said block surfaces by removing surrounding metallic material and corresponding ceramic material sufficient to electrically isolate said input and said output terminals from the surrounding electrically conductive material.

25

17. The method of claim 16 further comprising the steps of:

forming a third terminal on at least one of said block surfaces by removing  
said metallic material and corresponding dielectric material in an  
area surrounding said third terminal sufficient to electrically isolate  
5 said third terminal from the surrounding conductive metallic  
material;

said third terminal coupling an antenna to said first and second filters; and  
electrically coupling said first input terminal and said second output  
terminal to respective ones of said first and second filter circuits,  
10 said third terminal and to said first and second electrical filter circuit  
pattern elements forming a duplexer for transmit/receive RF  
communications.

---

18. An RF filter comprising:
- a block of dielectric material having multiple surfaces including at least one planar surface;
  - 5 a layer of electrically conductive material adhered to all of the multiple surfaces of said block of dielectric material;
  - a ground plane formed by at least one of said electrically conductive surfaces;
  - an electrical filter circuit pattern of multiple conductive elements being formed in said layer of electrically conductive material on at least
  - 10 said one planar surface;
- wherein said circuit pattern comprises:
- 15 a trench at least partially surrounding each of said conductive elements, said trench comprising recessed areas that extend through said conductive material and into corresponding dielectric material, said trenches having a predetermined shape determining the coupling capacitance between said conductive elements and said ground plane, said coupling capacitance determining an operating characteristic of said filter.

19. The RF filter of claim 18 wherein said predetermined shape of said trenches comprises predetermined depths and widths of said recessed areas.

5 20. The RF filter of claim 19 wherein said trenches are formed by ablatively removing said conductive material and corresponding dielectric material to said predetermined depths and widths.

21. A duplexer for an RF receiver/transmitter unit comprising:
- a block of dielectric material having multiple surfaces including at least one planar surface;
  - a layer of metallic material coating all of the multiple surfaces of said block of dielectric material;
  - 5 a ground plane formed by at least some of said metallic surfaces;
  - an RF receiver filter being formed in a first area of said at least one planar surface, and comprising:
    - 10 first plurality of conductive elements;
    - a first trench completely surrounding at least some of said conductive elements to electrically isolate them;
    - each first trench having a predetermined shape and comprising recessed areas having a predetermined depth and width and that extend through said metallic material and into corresponding dielectric material; and
    - 15 a first capacitive coupling between said first plurality of conductive elements and said ground plane that is determined by the depth and width of said recessed areas;
  - said first capacitive coupling determining the operating frequency of said RF receiver filter;
  - 20 an RF transmitter filter formed in a second different area of said at least one planar surface, and comprising:
    - a second plurality of conductive elements;
    - a second trench completely surrounding at least some of said second plurality of conductive elements to electrically isolate them;
    - 25 said second trenches having a predetermined shape and comprising second recessed areas having a second

predetermined depth and width that extend through said metallic material and into corresponding dielectric material; and

5 a second capacitive coupling between said second plurality of conductive elements and said ground plane that is determined by the second predetermined depth and width of said second recessed areas; said second capacitive coupling determining the operating frequency of said transmitter filter;

10 first and second terminals formed on at least one surface of said coated dielectric block for coupling RF signals to respective ones of said receiver filter and said transmitter filter; and

15 a third terminal for receiving an antenna connection, said third terminal being electrically coupled to said receiver filter and said transmitter filter for conveying RF signals between said antenna and said RF receiver and said RF transmitter.

22. The RF duplexer of claim 21 wherein said trenches are formed by ablatively removing said metallic material and said corresponding dielectric material to said predetermined depths and widths.

23. An RF filter comprising:
- a dielectric block having at least one planar surface;
  - a layer of electrically conductive material disposed on at least a portion of said dielectric block planar surface;
  - 5 a ground plane formed on at least one other block surface;
  - a pattern of dielectric material forming electrically conductive circuit elements on said dielectric block planar surface by electrically isolating said electrically conductive circuit elements from each other and from said ground plane;
  - 10 said electrically conductive circuit elements having a first elevation above said dielectric block planar surface;
  - at least one ablatively etched trench forming at least a portion of said pattern of dielectric material that electrically isolates said electrically conductive circuit elements; and
  - 15 said trench extending into said dielectric material one or more predetermined depths below said dielectric planar surface to electrically isolate said electrical circuit pattern elements.



24. The filter of claim 23 wherein:

at least 10% of said trench portion is formed by ablatively etching said pattern of dielectric material to electrically isolate said electrical circuit pattern elements.

5

25. The filter of claim 23 wherein:

said trench portion of said pattern of dielectric material electrically isolating said electrical circuit pattern elements is preferably in the range of from about 70% to about 90% thereof.

10

26. The filter of claim 23 wherein said trenches are formed by ablatively removing said metallic material and said dielectric material to said first and second predetermined depths and widths with a laser beam.

15

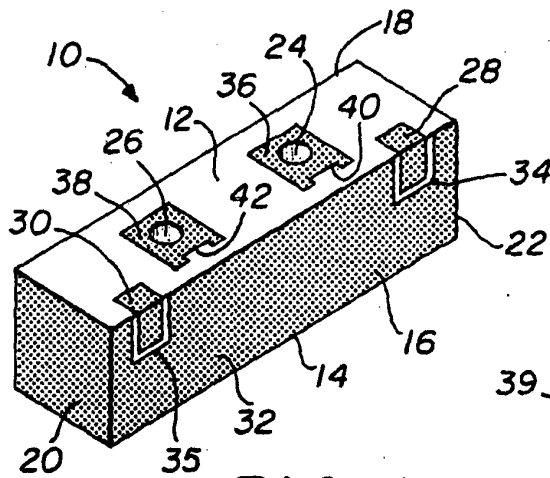

**FIG. 1**  
**PRIOR ART**

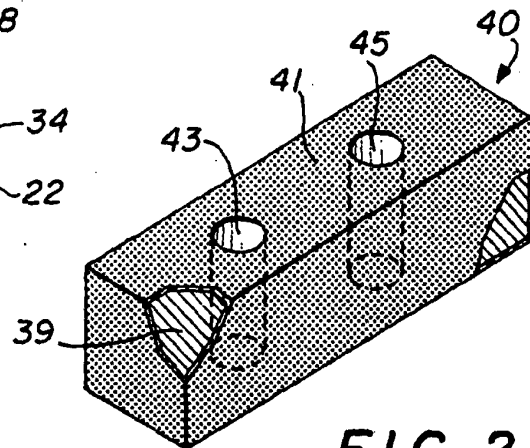

**FIG. 2**

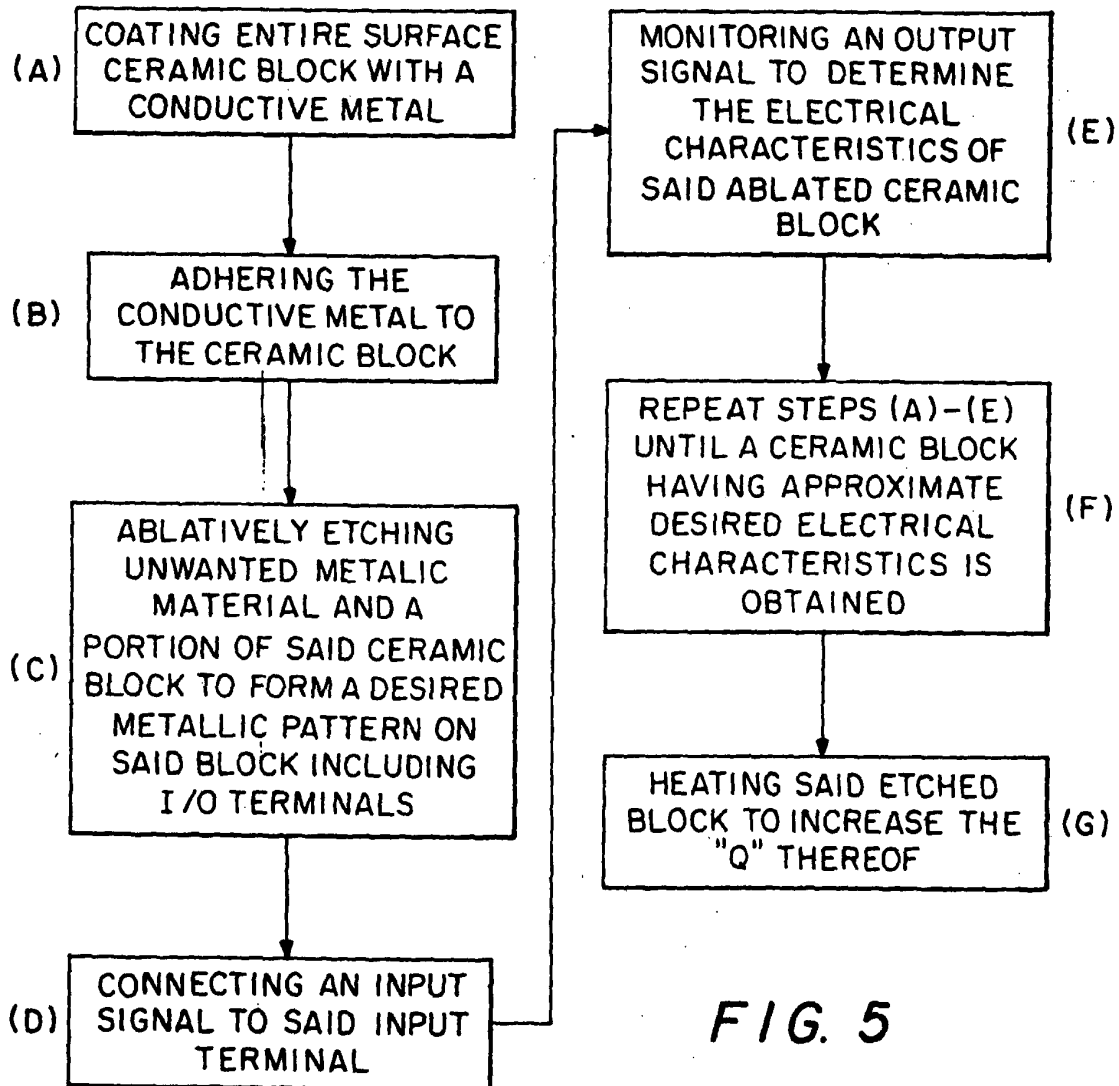

**FIG. 5**

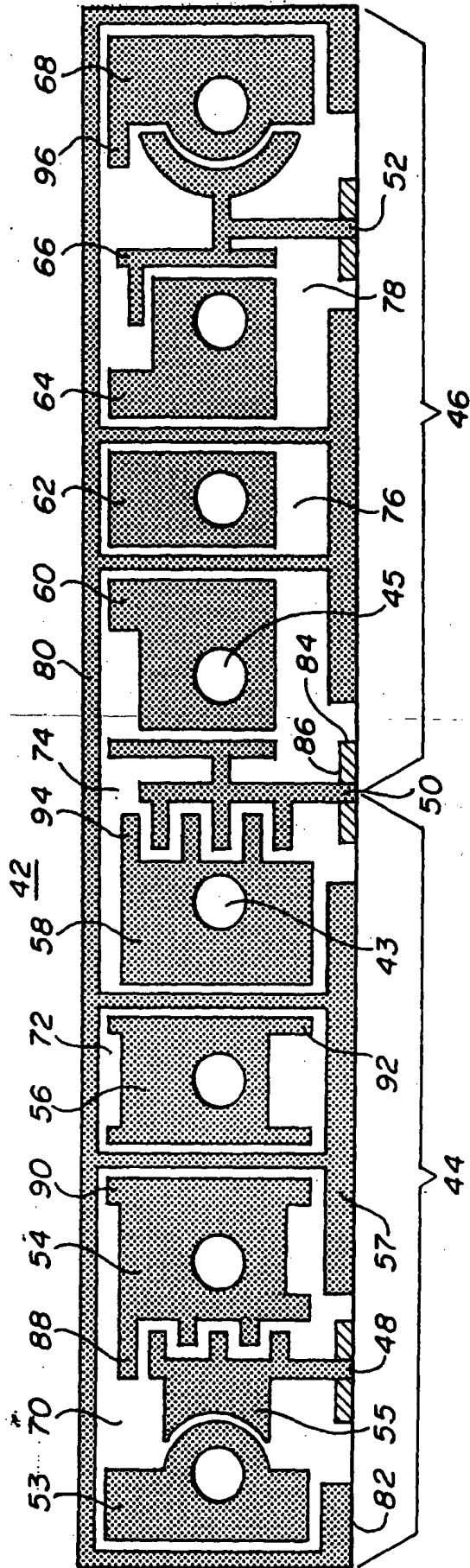

FIG. 3

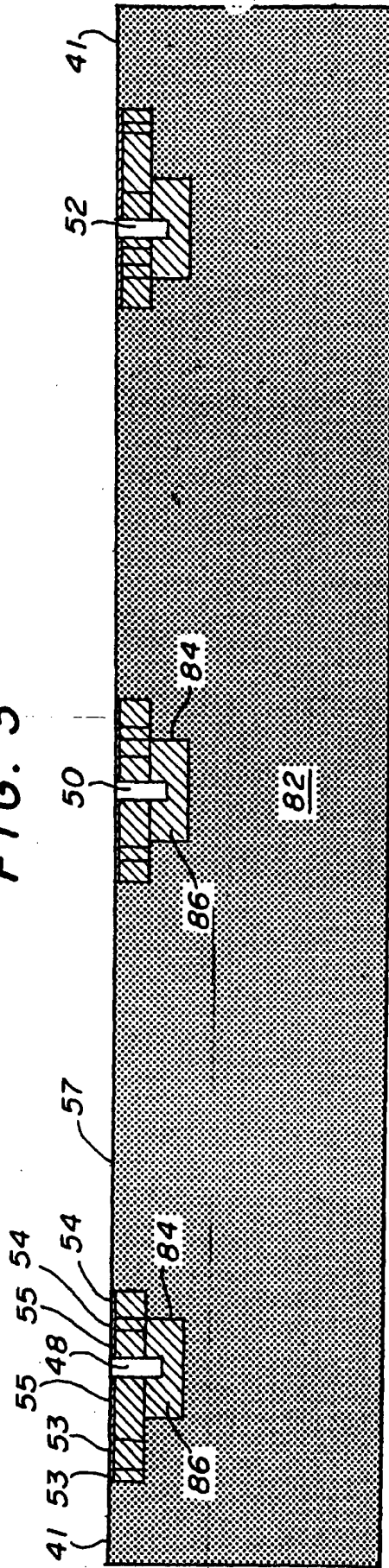
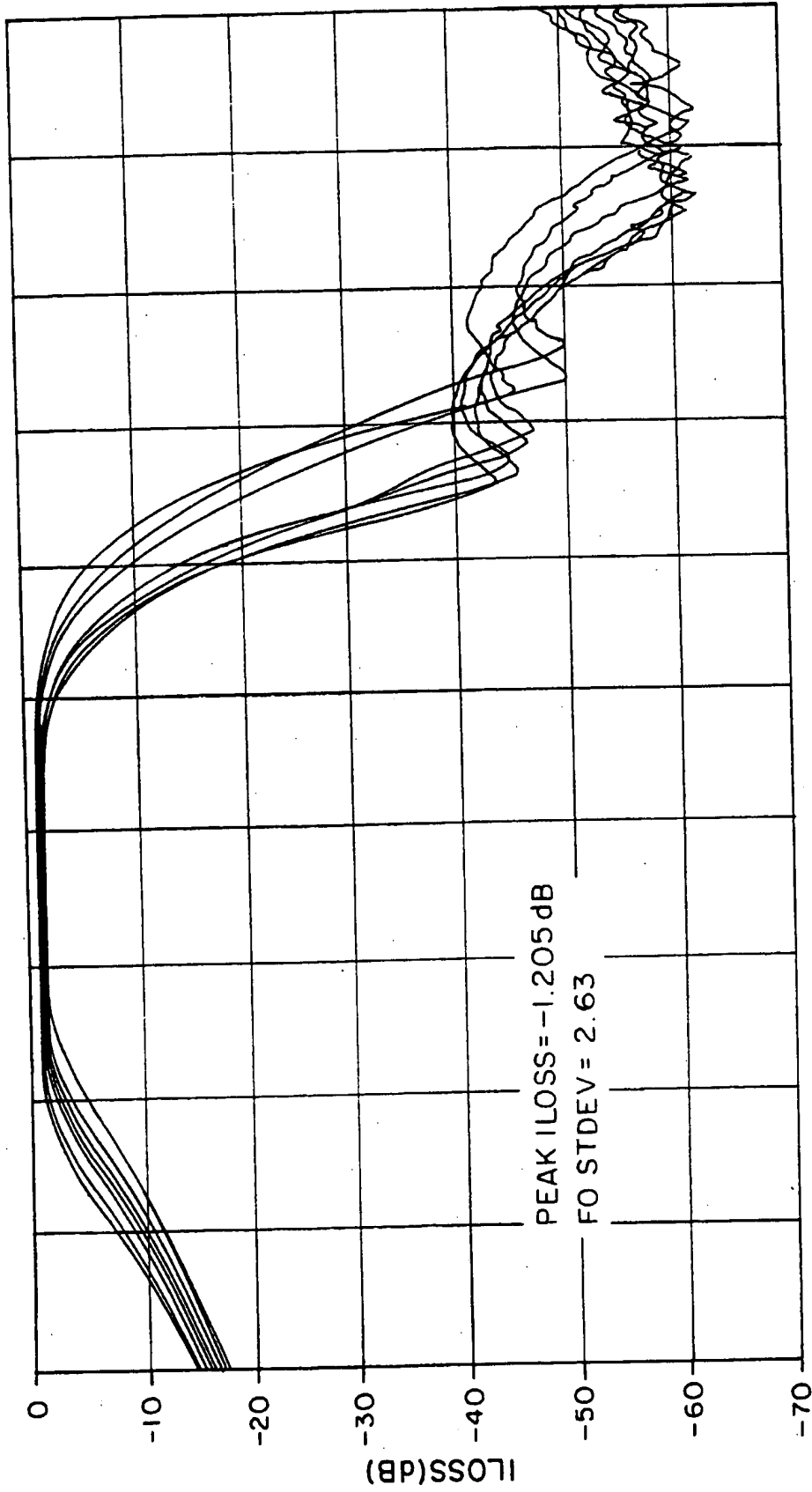

FIG. 4



FREQUENCY

FIG. 6

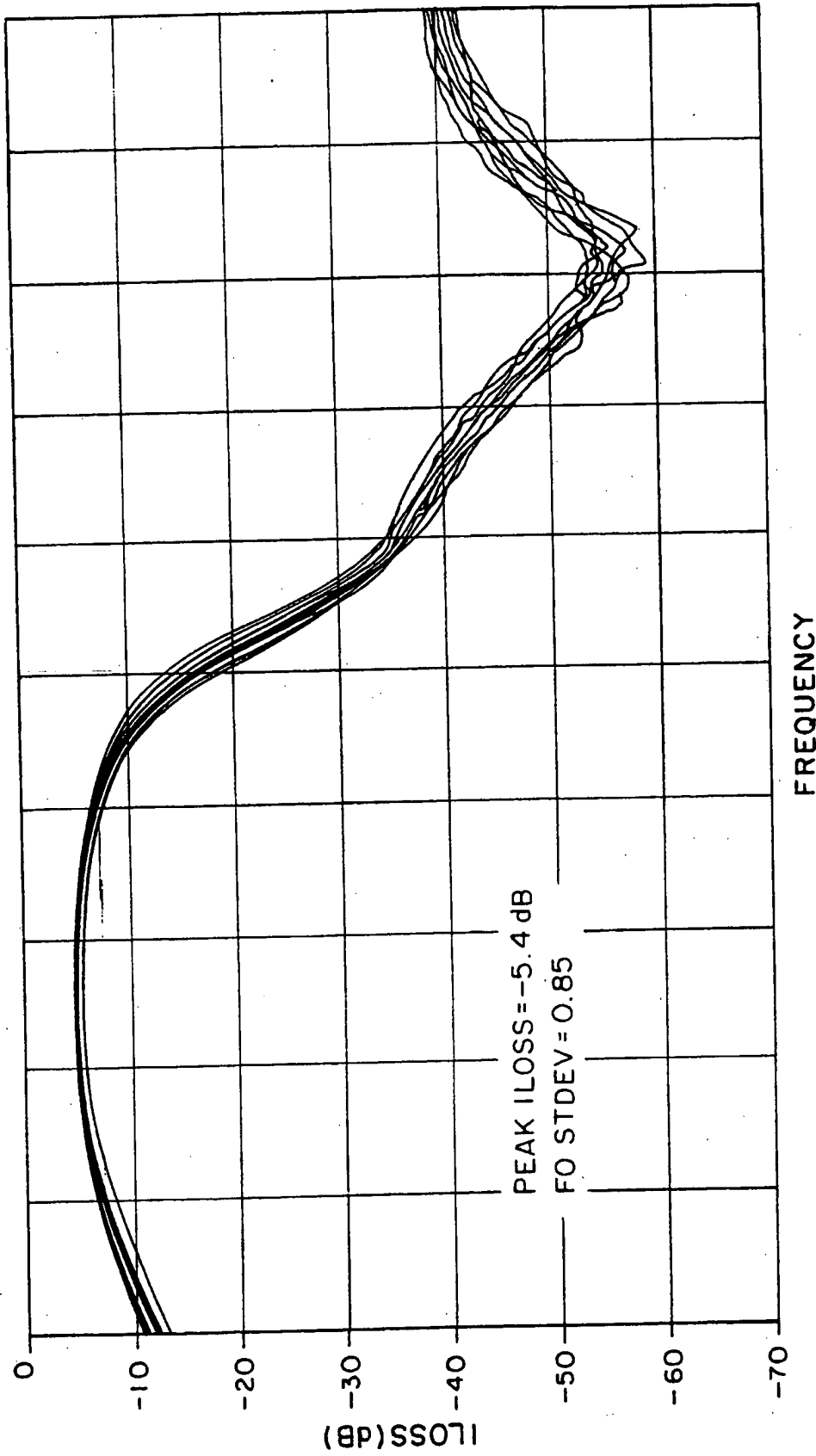

FIG. 7

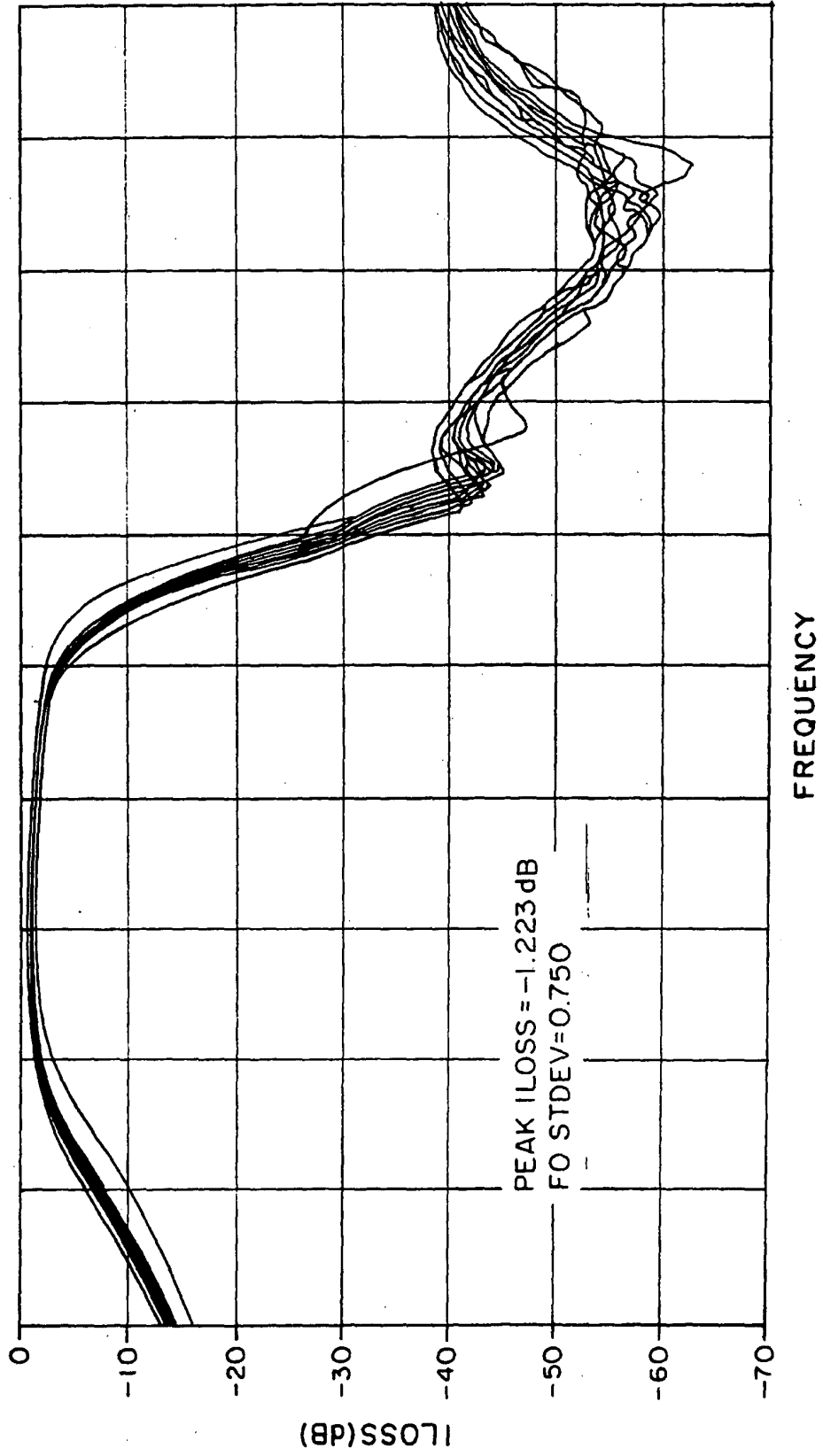

FIG. 8

# INTERNATIONAL SEARCH REPORT

International Application No  
**PCT/US 00/16138**

**A. CLASSIFICATION OF SUBJECT MATTER**  
**IPC 7 H01P11/00**

According to International Patent Classification (IPC) or to both national classification and IPC

**B. FIELDS SEARCHED**  
 Minimum documentation searched (classification system followed by classification symbols)  
**IPC 7 H01P**

Documentation searched other than minimum documentation to the extent that such documents are included in the fields searched

Electronic data base consulted during the international search (name of data base and, where practical, search terms used)  
**PAJ, EPO-Internal**

**C. DOCUMENTS CONSIDERED TO BE RELEVANT**

Category *	Citation of document, with indication, where appropriate, of the relevant passages	Relevant to claim No.
X	US 5 783 978 A (MATSUSHITA ELECTRIC IND. CO. LTD.) 21 July 1998 (1998-07-21) column 7, line 11 - line 26; figures 5A,B,6	1-6,8
X	EP 0 865 094 A (TAIYO YUDEN CO., LTD.) 16 September 1998 (1998-09-16) column 8, line 51 - line 57; figures 4,9,10	1,8
A	EP 0 798 803 A (NGK SPARK PLUG CO., LTD.) 1 October 1997 (1997-10-01) column 5, line 30 - line 34; figure 3  -/--	1,8,13, 16,18

Further documents are listed in the continuation of box C.       Patent family members are listed in annex.

- \* Special categories of cited documents :
- "A" document defining the general state of the art which is not considered to be of particular relevance
  - "E" earlier document but published on or after the international filing date
  - "L" document which may throw doubts on priority claim(s) or which is cited to establish the publication date of another citation or other special reason (as specified)
  - "O" document referring to an oral disclosure, use, exhibition or other means
  - "P" document published prior to the international filing date but later than the priority date claimed
  - "T" later document published after the international filing date or priority date and not in conflict with the application but cited to understand the principle or theory underlying the invention
  - "X" document of particular relevance; the claimed invention cannot be considered novel or cannot be considered to involve an inventive step when the document is taken alone
  - "Y" document of particular relevance; the claimed invention cannot be considered to involve an inventive step when the document is combined with one or more other such documents, such combination being obvious to a person skilled in the art.
  - "&" document member of the same patent family

Date of the actual completion of the international search <b>18 August 2000</b>	Date of mailing of the international search report <b>25/08/2000</b>
--	---

Name and mailing address of the ISA European Patent Office, P.B. 5818 Patentlaan 2 NL - 2280 HV Rijswijk Tel. (+31-70) 340-2040, Tx. 31 651 epo nl, Fax: (+31-70) 340-3016	Authorized officer  <b>Den Otter, A</b>
--	---

# INTERNATIONAL SEARCH REPORT

International Application No

PCT/US 00/16138

## C.(Continuation) DOCUMENTS CONSIDERED TO BE RELEVANT

Category *	Citation of document, with indication, where appropriate, of the relevant passages	Relevant to claim No.
A	EP 0 480 703 A (GENERAL ELECTRIC COMPANY) 15 April 1992 (1992-04-15) column 5, line 40 - line 42 column 7, line 44 -column 8, line 56; claim 1	1



# INTERNATIONAL SEARCH REPORT

Information on patent family members

International Application No

PCT/US 00/16138

Patent document cited in search report	Publication date	Patent family member(s)	Publication date
US 5783978 A	21-07-1998	JP 9008506 A	10-01-1997
EP 0865094 A	16-09-1998	JP 10276009 A	13-10-1998
		JP 10284903 A	23-10-1998
		JP 10284904 A	23-10-1998
		JP 10322104 A	04-12-1998
		US 6081174 A	27-06-2000
EP 798803 A	01-10-1997	JP 9321503 A	12-12-1997
		US 5844454 A	01-12-1998
EP 0480703 A	15-04-1992	US 5104480 A	14-04-1992
		DE 69125333 D	30-04-1997
		DE 69125333 T	02-10-1997
		JP 4280494 A	06-10-1992